



VALVE

ENGINEERING



OYSTER
SAMPLEMASTER
VALVE

OYSTER SAMPLERMASTER VALVE

OYSTER SAMPLERMASTER VALVE

The valve is designed to solve the problem of extracting samples of powder from reactors, driers and conveying systems in chemical and pharmaceutical plants with minimal disruption to the process.

The standard version of the valve is a non-intrusive piston valve with a sample port at an angle to the main body into which the sample falls under gravity when the valve is opened.

The valve is attached to the vessel by means of a tri-clamp or mounting flange. Mounting arrangements can be customised to order.

In the closed position the end of the piston is flush with the inside surface of the vessel.

The valve is manually operated turning the handwheel. An actuated version of the valve is also available.

The sample port is equipped with a purging valve which can be used to equalise pressure/vacuum to the outside.

KEY FEATURES :

- Excellent price/performance/quality ratio
- Easy and quick stripping and re-assembly, no special tools required
- Few components, simple and robust design for low maintenance costs and long product lifetime
- Flexibility of mounting options
- Simple manual operation via hand-wheel as standard
- Attachment for sample bottle via DIN, tri-clamp or bayonet mount
- Purging valve with tri-clamp attachment for improved clean-ability and easier use
- Choice of materials to resist the most aggressive products, acids and solvents: AISI 316L, HC22.

OPTIONAL FEATURES AVAILABLE:

- Automatic operation
- CIP version
- Crustbreaker
- High-containment sample taking
- Hastelloy C22 for components in contact with the product

FINISH

Contact surfaces: Mirror polished, Ramax<0.4 µm

Non-contact surfaces: Scotchbrite

Electro-polished finish available as an option

TECHNICAL CHARACTERISTICS

Metallic parts normally in contact with the product:

AISI316L, HC22

Metallic parts not normally in contact with the product:

AISI304L, AISI 316L

Piston material:

PTFE, AISI 316L, HC22

Piston diameter:

45 mm

Sample port diameter:

40 mm

Weight:

Approx.. 4.5 kg (depending on configuration)

Operating pressure:

-1/3.5 barg

Operating temperature:

30° / 150°C

Design pressure:

10 bar

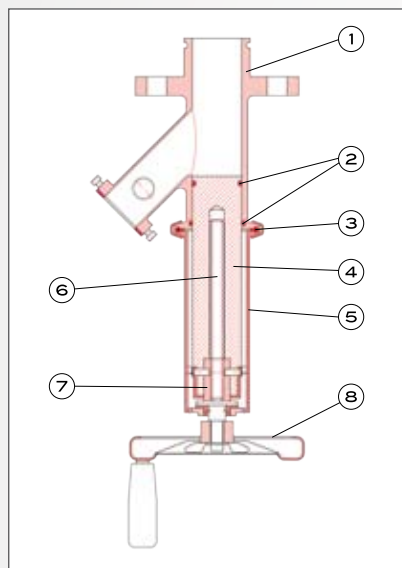

PARTS LIST AND MATERIALS

Description	Material
1. Valve body	AISI 316L, HC22
2. Piston o-rings	FEP, KAFLON
3. TC gasket	PTFE
4. Piston	PTFE
5. Lower body	AISI 316L
6. Drive screw	AISI 304
7. Drive bush	BRONZE
8. Handwheel	AISI 304

MOUNTING

The following options are available for mounting the valve to the host installation:

Tri-clamp

PN 6 flange

PN 10 flange

Customised to client's requirements

SIZES

The valve is available as standard in DN50 size with a 40mm sample port. Other sizes can be quoted on application.

CLASSIFICATION FOR POTENTIALLY EXPLOSIVE ATMOSPHERES:

In consideration of art 1.3a of the Directive 94/9/EC of the European parliament and the council of 23.03.1994 on the harmonization of the law of the member states concerning equipment and protection systems intended for use in potentially explosive atmospheres; this product is not within the scope of the directive 94/9/EC because it has no potential sources of ignition. This fact is also in accordance with the ATEX Guidelines 2005, point 5.2.1 about "Simple" mechanical devices.

The national and where necessary European rules for the installation and operation in hazardous areas of the Oyster Samplermaster Valve have to be considered by the user.